



*An Online PDH Course
brought to you by
CEDengineering.com*

Arc Flash Hazard Calculations in DC Systems

Course No: E03-035
Credit: 3 PDH

Velimir Lackovic, Char. Eng.



Continuing Education and Development, Inc.

P: (877) 322-5800
info@cedengineering.com

www.cedengineering.com

IEEE 1584 standard does not discuss arc flash hazard calculations in the DC systems. Standard NFPA-70E- 2000 provides a short calculation method. Therefore, the current literature is lacking calculations of arc flash hazard in DC systems. The necessary calculation steps are very similar to calculations in AC systems, however there are marked differences, particularly with respect to protection, cause of short - circuit currents in the DC electrical systems, and the current interruption devices in DC systems, which function fast to limit the energy let - through. Arc flash hazard calculation process in DC systems can be summarized as follows:

- Calculate the short-circuit currents in the DC systems. Fault currents in DC systems rise at a certain rate, depending upon the DC source.
- Calculate the arcing resistance and the arcing currents.
- Adjust the time–current characteristics of the protective equipment for increasing DC currents.
- Calculate the arc flash arcing time.
- Calculate the arc flash incident energy.

SHORT -CIRCUIT CURRENTS CALCULATIONS IN DC SYSTEMS

The short - circuit currents calculations in DC systems is vital for the design of distribution and protective devices used in DC systems and for arc flash assessment. The DC systems include DC motors, drives, controllers, battery power applications, emergency power supply systems, data - processing equipment, and computer DC power systems and transit systems. Maximum short - circuit currents have to be taken into account when choosing the rating of the electrical devices, like cables, buses, and associated equipment. The high - speed DC protective equipment may break the current before the peak is reached. It is mandatory to consider the current rate of rise and interruption time, in order to find the maximum current that will be actually obtained. Lower - speed DC protective elements may allow the peak to be reached before breaking current. For arc flash assessment, the operation of the protective elements needs to be calculated for the arcing currents. Even though the simplified methodologies for DC short - circuit current calculation are presented in some documents, calculation procedures are not that transparent. Unfortunately,

there is no ANSI/IEEE standard for calculation of short - circuit currents in DC installations. ANSI/IEEE C37.14 standard gives some guidelines. IEC standard 61660-1 is the only detailed document available on the subject. This standard discusses short - circuit currents calculations in DC auxiliary systems in power plants and substations, and does not present calculations in other big DC power systems, such as electrical railway traction and transit installations. The IEC standard discusses quasi-steady-state techniques for DC systems. The time change of the characteristics of major sources of DC short-circuit current from initiation to steady - state are presented, and adequate estimation curves and rules are presented. A dynamic simulation is a possibility, nevertheless, akin to short-circuit current computations in AC systems; the simplified methodologies are easy to use. However, these need to be checked by an actual simulation. Even though some documentation and examples of short - circuit currents in DC systems according to ANSI/IEEE documents are available, this course will use IEC equations and procedures because of the comprehensive nature of the IEC methodology. It is suggested that student gets a copy of IEC standard for complete appreciation of IEC methodology.

DC SHORT -CIRCUIT CURRENT SOURCES

Four types of DC sources have to be considered:

- Lead acid batteries
- DC motors
- Converters in three-phase bridge arrangement
- Smoothing capacitors

Figure 1 presents the normal short- circuit current time profiles of these sources, and Figure 2 presents the standard function used in the IEC standard. The following permissions are applicable:

I_k - quasi steady-state short-circuit current

i_p - peak short-circuit current

T_k - short-circuit duration

t_p - time to peak

τ_1 - rise time constant

τ_2 - decay time constant

The approximate function is expressed as:

$$i_1(t) = i_p \frac{1 - e^{-\frac{t}{\tau_1}}}{1 - e^{-\frac{t_p}{\tau_1}}} \quad (1)$$

$$i_2(t) = i_p [(1 - \alpha)e^{-(t-t_p)\tau_2} + \alpha] \quad (t \geq t_p) \quad (2)$$

$$\alpha = \frac{I_k}{i_p} \quad (3)$$

The quasi steady-state current I_k is assumed as the value at 1 second after the short – circuit start. If no certain maximum is present, as presented in Figure 1(a) for the converter current, then the value is determined only with Equation (1).

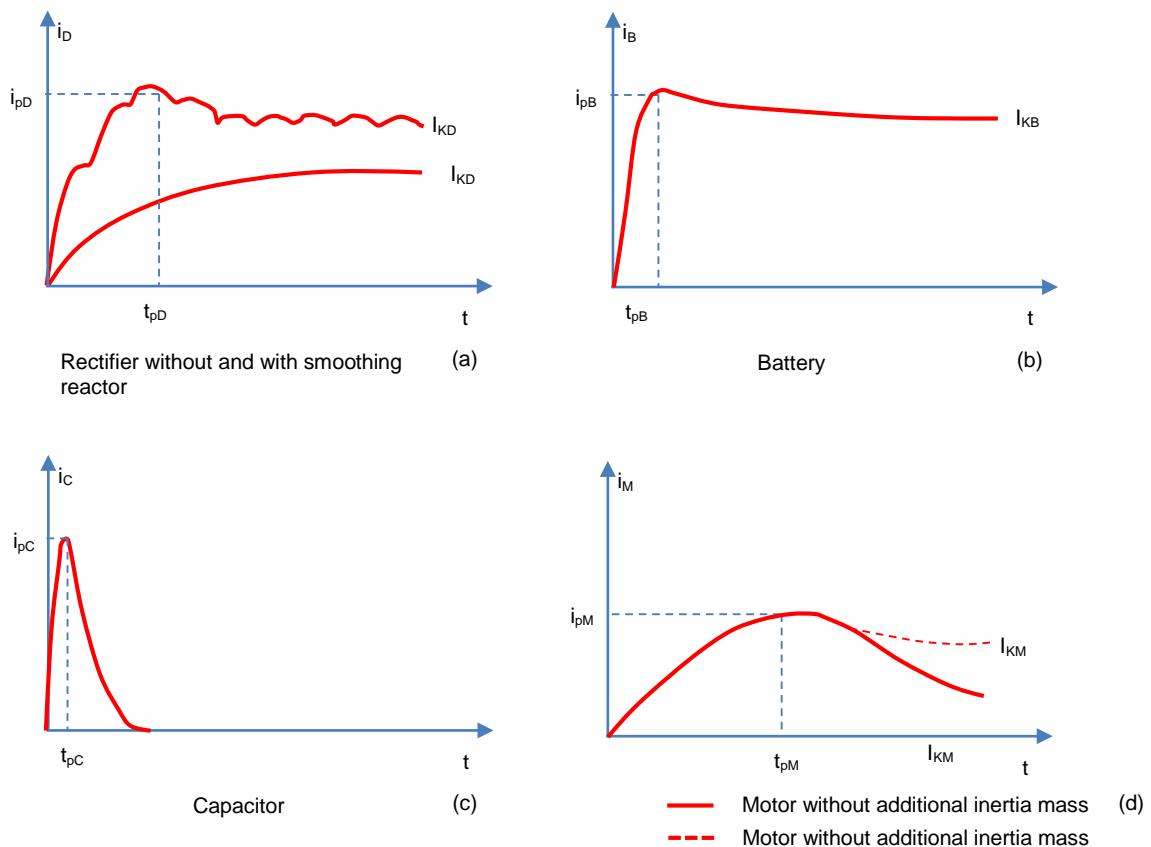

Figure 1. Short circuit profile of different DC sources: (a) rectifier with and without smoothing reactor, (b) Lead acid battery, (c) capacitor, and (d) DC motor with and without initial inertia mass.

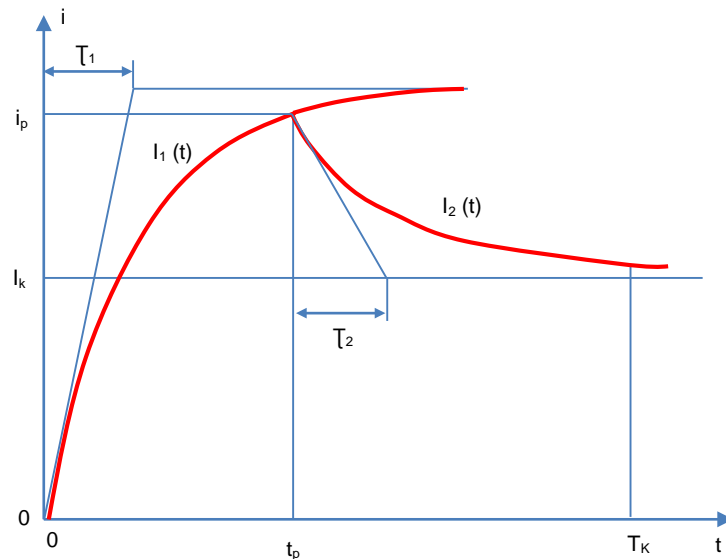

Figure 2. Standard short circuit function curve

IEC CALCULATION TECHNIQUES

Figure 3 presents a DC distribution system that has all four DC short - circuit currents. Two short-circuit positions are presented:

- (1) F_1 , without a common branch,
- (2) F_2 , through resistance and inductance, R_y and L_y of the common branch.

The short - circuit current at location F_1 is the short - circuit current summation of the four sources, as if these were acting alone through the series resistances and inductances. For short-circuit current computation at F_2 , the short-circuit currents are calculated same as for F_1 , but including R_y and L_y to the series circuit in each of the sources. Correction factors are applied, and the different time functions are added to the overall current time function. Whether it is the maximum or minimum short - circuit current calculation, the loads are neglected and the fault impedance is considered to be zero. For the peak short-circuit current, the following conditions can be applied:

- The conductor resistance is expressed at 20°C.
- The contact resistance is neglected

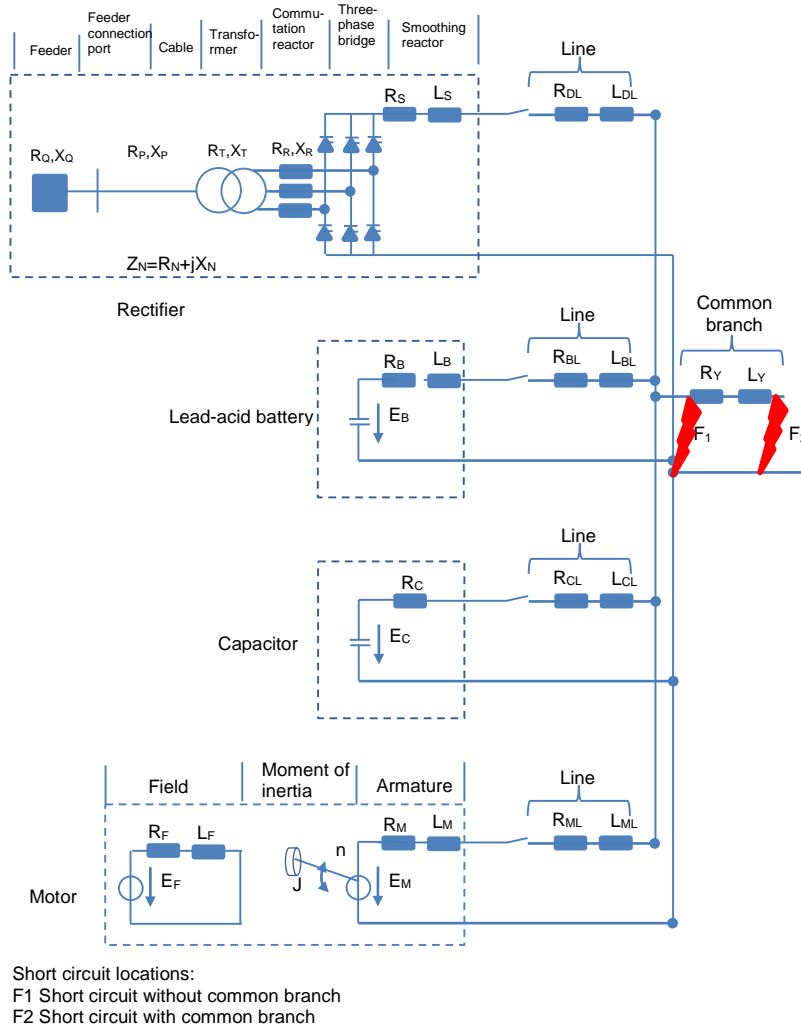

Figure 3. A DC distribution system for short-circuit current calculation

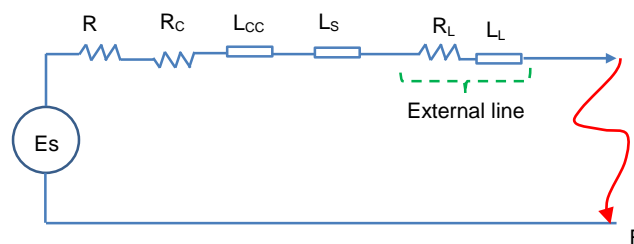

Figure 4. Equivalent battery computation short-circuit diagram including external resistance and inductance

It is important to note that:

- The controls for limiting the rectifier current are not effective.
- The diodes for the decoupling part are not considered.
- The battery is totally charged.
- The current limiting effects of fuses or other protective devices are neglected.

LEAD ACID BATTERY SHORT CIRCUIT CURRENT

The battery short-circuit equivalent diagram is presented in Figure 4. R_B is the battery internal resistance, E_B is the internal voltage, R_C is the cell connector resistance, L_{CC} is the inductance of the cell circuit in H, and L_{BC} is the inductance of the battery cells considered as bus bars. The internal cell inductance itself is 0. The line resistance and inductance are R_L and L_L . The equation for the given circuit can be written as follows:

$$iR + L \frac{di}{dt} = E_B \quad (4)$$

The solution can be found as:

$$i = \frac{E_B}{R} (1 - e^{-\left(\frac{R}{L}\right)t}) \quad (5)$$

The peak short - circuit current can be expressed as:

$$I_{Bsc} = \frac{E_B}{R} \quad (6)$$

and the initial maximum rate of rise of the current is determined by di/dt at time $t=0$. That can be written as:

$$\frac{di_B}{dt} = \frac{E_B}{L} \quad (7)$$

Going back to Figure 4, all resistance and inductance elements in the battery circuit need to be determined. The battery internal resistance R_B is calculated as:

$$R_B = R_{cell}N = \frac{R_p}{N_p} \quad (8)$$

where R_{cell} is the resistance/per cell, N is the total number of cells, R_p is the resistance per positive plate, and N_p is the total number of positive plates in a cell. R_p can be calculated as:

$$R_p = \frac{V_1 - V_2}{I_2 - I_1} \Omega / \text{positive plate} \quad (9)$$

where V_1 is the cell voltage, and I_1 is the associated rated discharge current per plate. In the similar way, V_2 is the cell voltage, and I_2 is the associated rated discharge current per plate at V_2 . The expression for the internal resistance is:

$$R_B = \frac{E_B}{100 \times I_{\text{ohr}}} \Omega \quad (10)$$

where I_{8hr} is the 8-hour battery rating to 1.75 V per cell at 25°C. Typically, R_B is available from supplier's records; it is not a constant value and depends on the battery charge state. A discharged battery will have considerably higher cell resistance.

To compute the maximum short-circuit current or the peak current according to IEC, the battery cell resistance R_B is multiplied by a 0.9 factor. Also, if the battery open-circuit voltage is not known, then use $E_B = 1.05 U_{NB}$, where $U_{NB}=2.0$ V/ cell for lead acid batteries. The peak current can be then expressed as:

$$i_{pB} = \frac{E_B}{R_{BBr}} \quad (11)$$

where i_{pB} is the battery peak short-circuit current and R_{BBr} is the battery circuit overall equivalent resistance, with R_B multiplied by a 0.9 factor. The time to peak and the rise time are obtained from curves in Figure 5, based on $1/\delta$, which is found as:

$$\frac{1}{\delta} = \frac{2}{\frac{R_{BBr} + 1}{L_{BBr} T_B}} \quad (12)$$

The time constant T_B is specified as equal to 30ms, and L_{BBr} is the complete equivalent inductance in the battery circuit to the fault point.

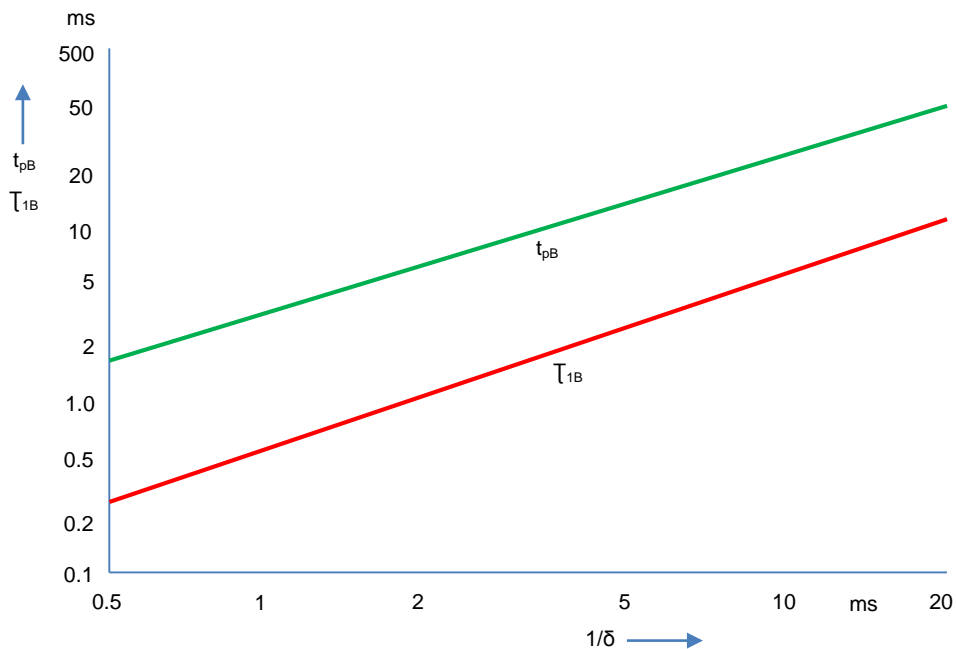

Figure 5. Time to peak t_{pk} and rise time constant τ_{1B} for the battery short -circuit

The decay time constant τ_{2B} is considered to be 100ms. Quasi steady-state short - circuit current is calculated as:

$$I_{kB} = \frac{0.95E_B}{R_{BB'r} + 0.1R_B} \quad (13)$$

This equation considers that the battery voltage decreases and the internal cell resistance increases after short - circuit.

Example 1

A 60-cell 120-V, lead acid battery has the following parameters:

- Battery rating = 200 Ah,
- 8 - hour rate of discharge to 1.75 V per cell.

Each cell has the following dimensions:

Height = 7.9 in (=200 mm), length=10.7 in (=272 mm), and width = 6.8 in (= 173 mm).

It is rack mounted, 30 cells per row, and the arrangement is presented in Figure 6. Cell interconnecting cables are 250 KCMIL, diameter = 0.575 in. The objective is to calculate the short-circuit current at the battery terminals. If the battery is linked through a 100 ft. cable to a circuit breaker, with cable resistance of $5m\Omega$, and cable inductance of $14\mu H$, determine the short-circuit current at breaker terminals. The battery resistance can be calculated using Equation (10). Taking into account cell voltage of 1.75 V per cell, the following can be written:

$$R_B = \frac{E_B}{100 \times I_{8hr}} = \frac{120}{100 \times 200} = 6 m\Omega$$

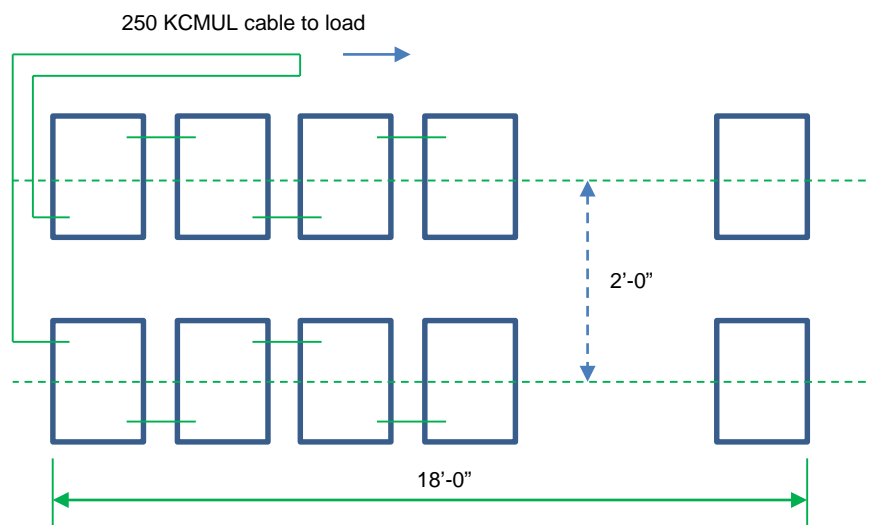

Figure 6. Battery system configuration for short -circuit current calculation

The battery provider gives the following formula for determining the battery resistance:

$$R_B = \frac{31 \times E_B}{I_{shr}} \text{ m}\Omega \quad (14)$$

Using the given parameters, the battery resistance is 18.6m Ω . Battery connectors have a complete length of 28 ft., size 250 KCMIL. The battery circuit inductance L_c is the sum of the cell circuit inductances (L_{CC}) plus the inductance of the battery cells, L_{CB} . The inductance of two round conductors of radius r , separated at a distance d , can be calculated as:

$$L = \frac{\mu_0}{\pi} \left(0.25 + \ln \frac{d}{r} \right) \quad (15)$$

where μ_0 is the permeability in vacuum = $4\pi \times 10^{-7}$ H/m. From Figure 6, the distance $d=24$ in. and r , the radius of 250 KCMIL conductor, is 0.2875 in. Putting these values in Equation (12), the inductance is 1.87 μ H/m for the loop length. Hence, for an 18 ft. loop length the inductance is $L_{CC} = 10.25 \mu$ H. The battery cell inductance can be found out by treating each row of cells like a bus bar. Hence, the two rows of cells are equivalent to parallel bus bars at a spacing $d=24$ in. The height of the bus bar h =height of the cell=7.95 in., and the width of the bus bars w =width of the cell=6.8 in. The expression for bus bar inductance in this arrangement is:

$$L = \frac{\mu_0}{\pi} \left(\frac{3}{2} + \ln \frac{d}{h+w} \right) \quad (16)$$

This equation gives inductance in H per meter loop length. Replacing the values, for an 18-ft loop length, inductance is $L_{BC}=4.36 \mu$ H. Hence, the complete inductance is 14.61 μ H. The overall battery circuit resistance, without external cable, is $0.9 \times 18.6 + 1.498=18.238$ m Ω . The battery voltage of 120 V is multiplied by 1.05 factor. Hence, the peak short-circuit current can be calculated as:

$$i_{PB} = \frac{E_B}{R_{BBr}} = \frac{1.05 \times 120}{18.238 \times 10^{-3}} = 6908.6 \text{ A}$$

$1/\delta$ is found out from Equation (15):

$$\frac{1}{\delta} = \frac{2}{\frac{18.238 \times 10^{-3}}{14.61 \times 10^{-6}} + \frac{1}{30 \times 10^{-3}}} = 1.56 \text{ ms}$$

From Figure 5, the time to peak is around 4.3ms, and the rise time constant is

0.75ms. Quasi steady-state short-circuit current can be determined as:

$$I_{kB} = \frac{0.95 \times 120 \times 10^3}{18.238 + 0.1(18.6)} = 5956 \text{ A}$$

The calculations that consider external cable are similarly completed. The cable resistance is 5 mΩ and inductance is 14 μH. Hence, $R_{BBr} = (0.9)(18.6) + 1.498 + 5 = 23.24 \text{ m}\Omega$. This gives a peak current of 5422 A; $1/\delta = 2.40\text{ms}$ and time to peak is 5.4ms. The rise time constant is 1.3ms, and the quasi steady-state short-circuit current is 4796 A. The short-circuit current curve is presented in Figure 7 (a).

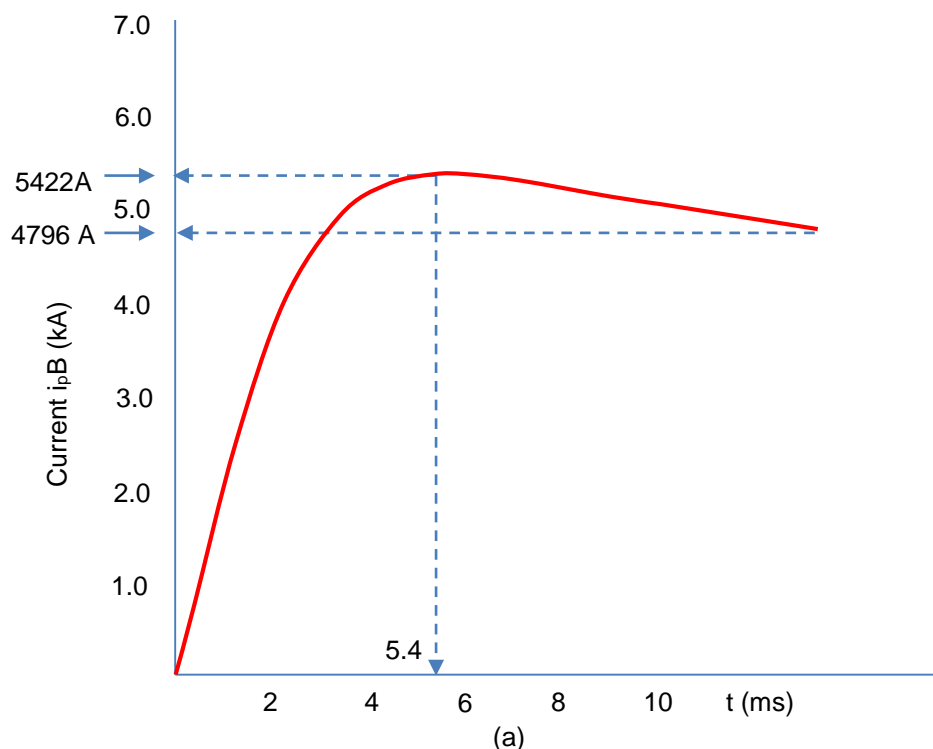

Figure 7 (a). Calculated battery short-circuit time–current curve

DC MOTOR AND GENERATOR SHORT CIRCUIT CURRENT

The resistance and inductance network of the short circuit of a DC motor with a separately excited field is presented in Figure 3. The resistance and inductance can be expressed as:

$$\begin{aligned} R_{MB} &= R_M + R_{ML} + R_y \\ L_{MB} &= L_M + L_{ML} + L_y \end{aligned} \quad (17)$$

where R_M and L_M are the resistance and inductance, of the armature circuit, including the brushes. R_{ML} and L_{ML} are the resistance and inductance of the conductor in the motor circuit, and R_y and L_y are the resistance and inductance of the common branch, if present. The time constant of the armature circuit up to the short-circuit point, τ_M can be expressed as:

$$\tau_M = \frac{L_{MB}}{R_{Mb}} \quad (18)$$

The quasi steady-state short-circuit current can be expressed as:

$$I_{KM} = \frac{L_F}{L_{0F}} \frac{U_{rM} - I_{rM}R_M}{R_{MB}} \quad \text{when } n = n_n = \text{constant}$$

$$I_{kM} \rightarrow 0 \quad \text{when } n \rightarrow 0 \quad (19)$$

where:

L_F - equivalent saturated inductance of the field circuit on short circuit

L_{0F} - equivalent unsaturated inductance of the field circuit at no load

U_{rM} - rated voltage of the motor

I_{rM} - rated motor current

n - motor speed

n_n - rated motor speed.

The motor peak short - circuit current can be expressed as:

$$i_{pM} = k_M \frac{U_{rM} - I_{rM}R_M}{R_{MB}} \quad (20)$$

At normal speed or decreasing speed with $\tau_{mec} \geq 10\tau_F$, the factor $k_M = 1 \kappa$, where τ_{mec} is the mechanical time constant, calculated as:

$$\tau_{mec} = \frac{2\pi J n_0 R_{MB} I_{rM}}{M_r U_{rM}} \quad (21)$$

where J is the moment of inertia, and M_r is the rated motor torque. The field circuit time constant τ_F is expressed as:

$$\tau_F = \frac{L_F}{R_F} \quad (22)$$

For $\tau_{mec} \geq 10\tau_F$, the time to peak and time constant are calculated as:

$$\tau_{pM} = k_{1M} \tau_M$$

$$\tau_{1M} = k_{2M} \tau_M \quad (23)$$

The factors k_{1M} and k_{2M} are taken from curves in Figure 8, and they depend on τ_F/τ_M and L_F/L_{OF} . For decreasing speed with $\tau_{mec} < 10\tau_F$, the factor k_M depends on $1/\delta = 2\tau_M$ and ω_0 :

$$\omega_0 = \sqrt{\frac{1}{\tau_{mec}\tau_M} \left(1 - \frac{I_{rM}R_M}{U_{rM}}\right)} \quad (24)$$

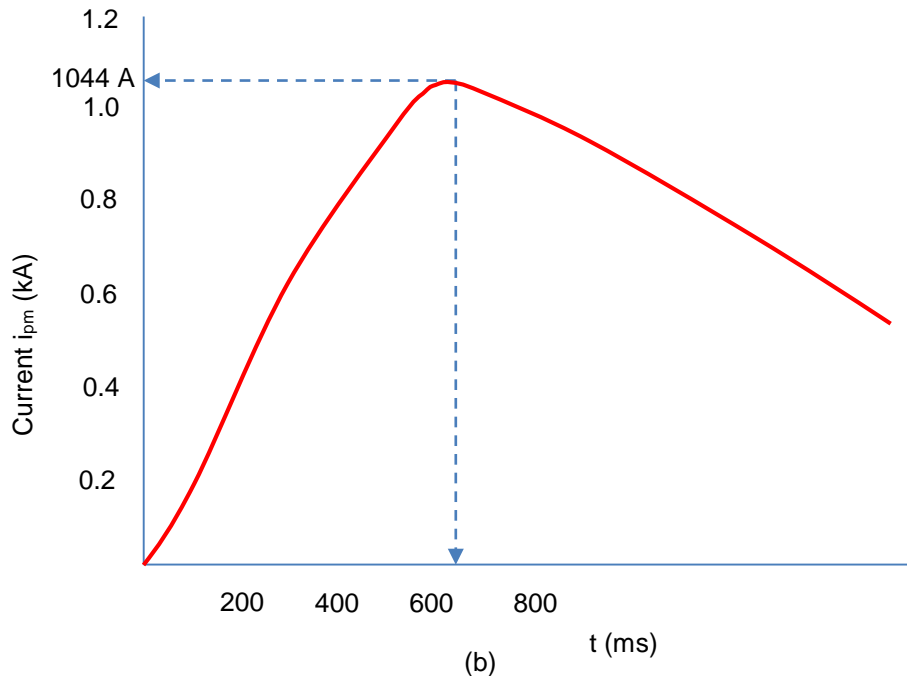

Figure 7(b). DC motor calculated short-circuit time–current curve

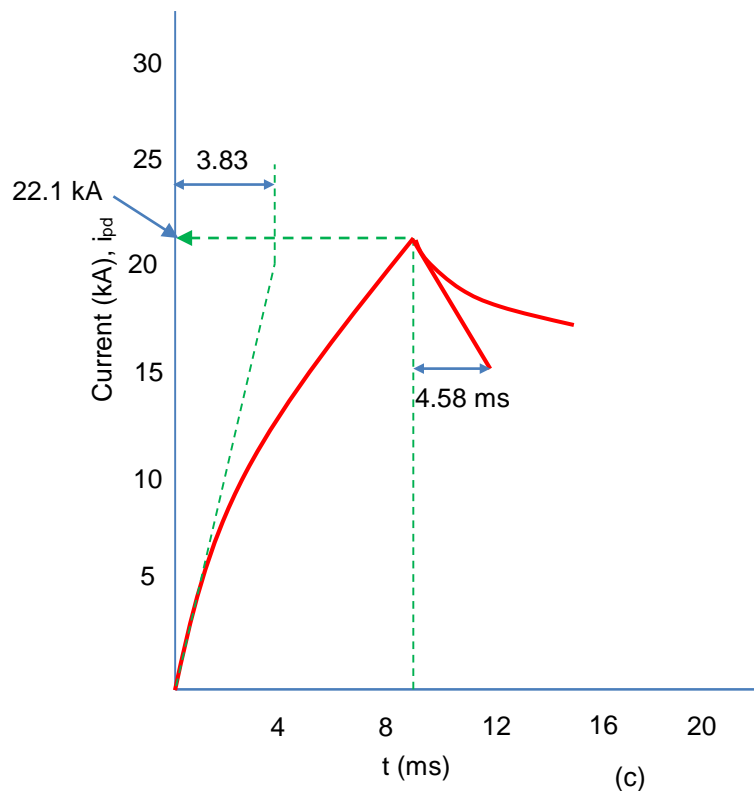

Figure 7 (c). Rectifier calculated short-circuit time–current curve

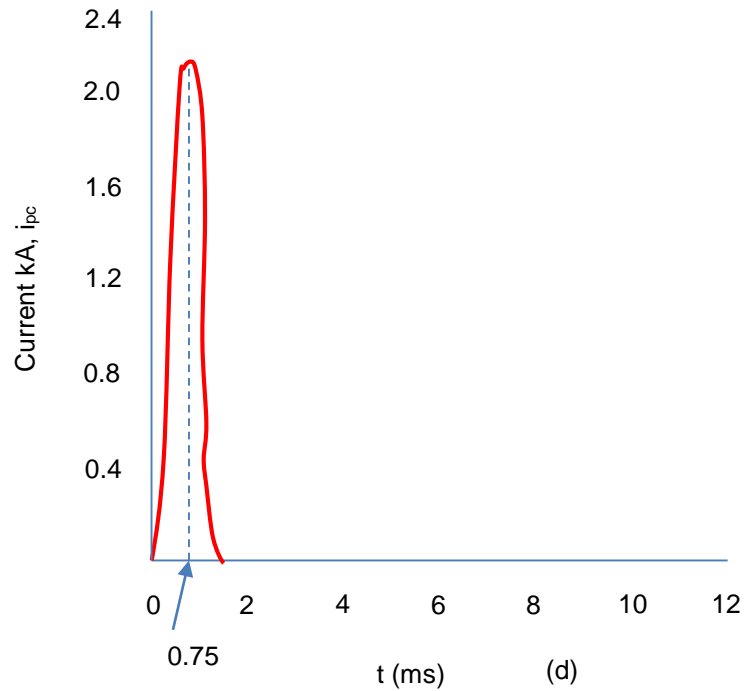

Figure 7 (d). Calculated capacitor short-circuit time-current curve

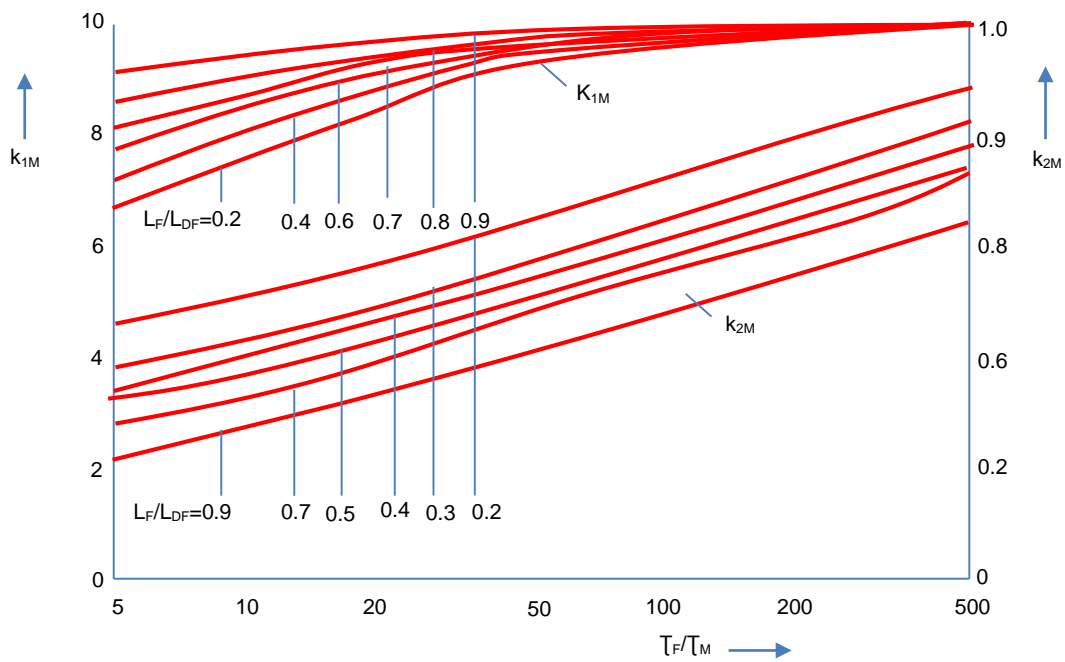

Figure 8. Factors k_{1M} and k_{2M} for calculating the time to peak t_{pM} and the rise time τ_{1M} for normal and decreasing speed with $\tau_{mec} \geq 10\tau_F$

where ω_0 is the undamped natural angular frequency and δ is the decay coefficient; k_M is derived from the curves. For decreasing speed with $\tau_{mec} < 10\tau_F$, the time to peak τ_M is determined from a curve in shown in the Figure 8, and the rise time

constant is expressed as:

$$\tau_{1M} = k_{3M}\tau_M \quad (25)$$

where the factor k_{3M} is again read from a curve in the IEC standard. Regarding the decay time constant τ_{2M} , for nominal speed or decreasing speed with $\tau_{mec} \geq 10\tau_F$:

$$\begin{aligned} \tau_{2M} &= \tau_F \quad \text{when } n = n_n = \text{const.} \\ \tau_{2M} &= \frac{L_{of}}{L_F} k_{4M} \tau_{mec} \quad \text{when } n \rightarrow 0 \text{ with } \tau_{mec} \geq 10\tau_F \end{aligned} \quad (26)$$

For decreasing speed with $\tau_{mec} < 10\tau_F$:

$$\tau_{2M} = k_{4M} \tau_{mec} \quad (27)$$

where k_{4M} is again read from a curve in the IEC standard. Hence, the IEC calculation methodology asks for detailed motor parameters and the use of a number of graphical relations in the standard. The rise and decay time constants are related to $\tau_{mec} < 10\tau_F$ or $\tau_{mec} \geq 10\tau_F$.

Example 2

Calculate the fault current for a terminal fault on a 115 V, 1150 rpm, six-pole, 15-HP motor. The armature current is 106 A, the armature and brush circuit resistance is 0.1Ω , and the inductance in the armature circuit is 8 mH; $\tau_F = 0.8$ second, $\tau_{mec} > 10\tau_F$, $L_F/L_{OF}=0.5$, and $\tau_{mec} = 20$ seconds. There is no external resistance or inductance in the motor circuit. Hence, $R_{MBr}=R_M=0.10 \Omega$. IEC regulations are not precise about the motor circuit resistance, or how it should be calculated or ascertained. The time constant is calculated as:

$$\tau_M = \frac{L_M}{R_M} = \frac{8 \times 10^{-3}}{0.10} = 80 \text{ ms}$$

The quasi-steady-state current from Equation (19) is

$$0.5 \left(\frac{115 - (0.10)(106)}{0.10} \right) = 522 \text{ A}$$

From Equation (20), the peak current is 1044 A, because for $\tau_{mec} > 10\tau_F$, factor k_M in Equation (20)=1. The time to peak and time constant are expressed with Equation (23). From Figure 3, and for $\frac{\tau_F}{\tau_M} = 10$ and $L_F/L_{OF}=0.5$, factor $k_{1M}=8.3$ and $k_{2M}=0.370$. Hence, the time to peak is 640ms and the time constant $\tau_{1M} = 29.6 \text{ ms}$. The short -

circuit curve is presented in Figure 7(b).

RECTIFIER SHORT -CIRCUIT CURRENT

The common time–current curve for rectifiers short-circuit is presented in Figure 9. The maximum current is reached at one half-cycle after the fault happens. The peak at half-cycle is caused by the same process that makes a DC offset in AC short – circuit calculations. The peak magnitude depends on X/R ratio, the AC system source reactance, rectifier transformer impedance, and the resistance and reactance through which the current goes in the DC system. The addition of resistance or inductance to the DC system decreases this peak, and, depending on the components' magnitude, the peak may be completely eliminated, with a smoothing DC reactor as presented in Figure 1(a). The region A shown in Figure 9 covers the initial current rise, the peak current happens in region B, and region C covers the time after one cycle until the current is interrupted. The initial rate of rise of the DC fault current for a bolted fault changes with the magnitude of the sustained short - circuit current. The addition of inductance to the DC circuit tends to reduce the rate of rise.

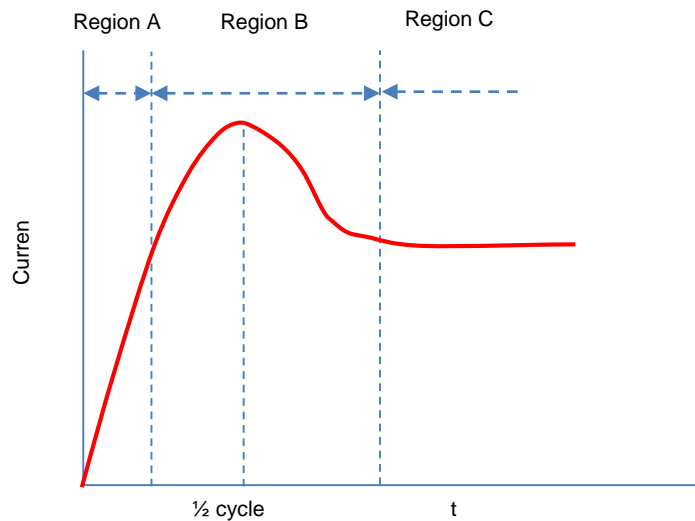

Figure 9. Rectifier short-circuit current

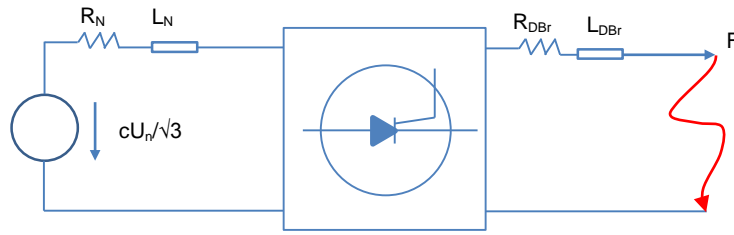

Figure 10. Rectifier equivalent short -circuit current circuit

The equivalent short-circuit scheme is presented in Figure 10. The maximum DC fault current is determined by the minimum impedance Z_{Qmin} , which is calculated from the maximum fault current I_{kQmax} of the AC system:

$$Z_{Qmin} = \frac{cU_n}{\sqrt{3}I''_{kQmax}} \quad (28)$$

The minimum DC current is expressed as:

$$Z_{Qmax} = \frac{cU_n}{\sqrt{3}I''_{kQmin}} \quad (29)$$

In Figure 10 the resistance and inductances on the AC side are:

$$\begin{aligned} R_N &= R_Q + R_P + R_T + R_R \\ X_N &= X_Q + X_P + X_T + X_R \end{aligned} \quad (30)$$

where R_Q and X_Q are the fault resistance and reactance of the AC source referred to the rectifier transformer secondary, R_P and X_P are the fault resistance and reactance of the power supply cable referred to the transformer secondary side, R_T and X_T are the fault resistance and reactance of the rectifier transformer referred to the transformer secondary side, and R_R and X_R are the fault resistance and reactance of the commutating reactor. Similarly, on the DC side:

$$\begin{aligned} R_{DBr} &= R_S + R_{DL} + R_y \\ L_{DBr} &= L_S + L_{DL} + L_y \end{aligned} \quad (31)$$

where R_S , R_{DL} , and R_y are the resistances of the DC saturated smoothing reactor, the conductor in the rectifier circuit, and the common branch, respectively, and L_S , L_{DL} , and L_y are the corresponding inductances. The quasi steady-state short-circuit current expressed as:

$$i_{kD} = \chi_D \frac{3\sqrt{2}}{\pi} \frac{cU_n}{\sqrt{3}Z_N} \frac{U_{rTLV}}{U_{rTHV}} \quad (32)$$

where Z_N is the impedance on the AC side of three-phase network. The factor λ_D as a function of R_N/X_N and R_{DBr}/R_N is determined from the curves included in the IEC standard. Optionally, it is calculated by the following equation:

$$\chi_D = \sqrt{\frac{1 + \left(\frac{R_N}{X_N}\right)^2}{1 + \left(\frac{R_N}{X_N}\right)^2 \left(1 + 0.667 \left(\frac{R_{DBr}}{R_N}\right)^2\right)}} \quad (33)$$

The peak short circuit current is expressed as:

$$i_{pD} = k_D I_{kD} \quad (34)$$

where the factor k_D depends on:

$$\frac{R_N}{X_N} \left[1 + \frac{2R_{DBr}}{3R_N}\right] \quad \text{and} \quad \frac{L_{DBr}}{L_N} \quad (35)$$

k_D is determined from the curves in the IEC standard or from the following expression:

$$k_D = \frac{i_{pD}}{I_{kD}} = 1 + \frac{2}{\pi} e^{-\left(\frac{\pi}{3} + \phi_D\right) \cot \phi_D} \sin \phi_D \left(\frac{\pi}{2} - \arctan \frac{L_{DBr}}{L_N}\right) \quad (36)$$

Where

$$\phi_D = \arctan \frac{1}{\frac{R_N}{X_N} \left(1 + \frac{2R_{DBr}}{3R_N}\right)} \quad (37)$$

Time to peak t_{pD} , when $k_D \geq 1.05$ is expressed as:

$$t_{pD} = (3k_D + 6) \text{ ms} \quad \text{when} \quad \frac{L_{DBr}}{L_N} \leq 1$$

$$t_{pD} = \left[(3k_D + 6) + 4 \left(\frac{L_{DBr}}{L_N} - 1\right)\right] \text{ ms} \quad \text{when} \quad \frac{L_{DBr}}{L_N} > 1 \quad (38)$$

If $k_D < 1.05$, the maximum current in comparison with the quasi steady-state fault current, is neglected, and $t_{pD} = T_k$ (fault duration) is used. The rise time constant for 50 Hz is expressed as:

$$\tau_{ID} = \left[2 + (k_D - 0.9) \left(2.5 + 9 \frac{L_{DBr}}{L_N}\right)\right] \text{ ms} \quad \text{when} \quad k_D \geq 1.05$$

$$\tau_{ID} = \left[0.7 + \left[7 - \frac{R_N}{X_N} \left(1 + \frac{2L_{DBr}}{3L_N}\right)\right] \left(0.1 + 0.2 \frac{L_{DBr}}{L_N}\right)\right] \text{ ms} \quad \text{when} \quad k_D < 1.05 \quad (39)$$

For simplification purposes:

$$\tau_{ID} = \frac{1}{3} t_{pD} \quad (40)$$

The decay time constant τ_{2D} for 50 Hz is expressed as:

$$\tau_{2D} = \frac{2}{\frac{R_N}{X_N} (0.6 + 0.9 \frac{R_{DBr}}{R_N})} \text{ ms} \quad (41)$$

Example 3

A three-phase rectifier is connected on the AC side to a three-phase, 480–120 V, 100-kVA transformer with percentage $Z_T=3\%$ and $X/R=4$. The 480-V source short-circuit MVA is 30, and the X/R ratio=6. The DC side smoothing inductance is $5 \mu\text{H}$, and the cable connection resistance is 0.002Ω . The objective is to find out and plot the fault current profile at the end of the cable on the DC side. Based on the AC side parameters, the source impedance in series with the transformer impedance referred to the rectifier transformer secondary side can be expressed as:

$$R_Q + jX_Q = 0.00008 + j0.00048 \Omega$$

$$R_T + jX_T = 0.001 + j0.00419 \Omega$$

Hence:

$$R_N + jX_N = 0.0011 + j0.004671 \Omega$$

On the DC side:

$$R_{DBr} = 0.002 \Omega \text{ and } L_{DBr} = 5\mu\text{H}$$

This further gives:

$$\frac{R_N}{X_N} = 0.24 \text{ and } \frac{R_{DBr}}{R_N} = 2$$

Find χ_D from Equation (33):

$$\chi_D = \sqrt{\frac{1 + (0.24)^2}{1 + (0.24)^2(1 + 0.667)(2.0)^2}} = 0.897$$

Hence, the quasi-steady-state current is found from Equation (32):

$$I_{kD} = (0.897) \left(\frac{3\sqrt{2}}{\pi} \right) \left(\frac{1.05 \times 480}{\sqrt{3} \times 0.0048} \right) \left(\frac{120}{480} \right) = 18.36 \text{ kA}$$

To find the peak current, compute the equation ratios:

$$\frac{R_N}{X_N} \left(1 + \frac{2 R_{DBr}}{3 R_N} \right) = (0.24)(1 + 0.667 \times 2) = 0.56$$

$$\frac{L_{DBr}}{L_N} = \frac{5 \times 10^{-6}}{0.0128 \times 10^{-3}} = 0.392$$

Compute k_D from Equations (36) and (37). From Equation (37) it can be found:

$$\phi_D = \tan^{-1} \frac{1}{0.24} \left(\frac{1}{1 + 0.667(2)} \right) = 60.75^\circ$$

and from Equation (36) , $k_D = 1.204$. Therefore, the peak short-circuit current is:

$$i_{pD} = k_D I_{kD} = 1.204 \times 18.36 = 22.10 \text{ kA}$$

The time to peak is expressed by Equation (38) and is equal to:

$$t_{pD} = (3k_D + 6)ms = (3 \times 1.204 + 6) = 9.62 \text{ ms}$$

The rise time constant is determined by Equation (39) and is equal to 3.83ms, and the decay time constant is determined by Equation (41) and equals 4.58ms.

The current curve is presented in Figure 7(c), which displays the calculated values. The intermediate curve shape can be correctly plotted using Equations (1) and (2).

CHARGED CAPACITOR SHORT CIRCUIT CURRENT

The resistance and inductance in the capacitor circuit shown in Figure 3 are:

$$\begin{aligned} R_{CBr} &= R_C + R_{CL} + R_y \\ L_{CBr} &= L_{CL} + L_y \end{aligned} \quad (42)$$

where R_C is the capacitor equivalent DC resistance, and R_{CL} and L_{CL} are the resistance and inductance of a conductor in the capacitor circuit. The steady-state fault current of the capacitor is zero, and the peak current is expressed as:

$$i_{pC} = k_C \frac{E_C}{R_{CBr}} \quad (43)$$

where E_C is the capacitor voltage before the fault, and k_C is obtained from curves in the IEC standard based on:

$$\frac{1}{\delta} = \frac{2L_{CBR}}{R_{CBR}}$$

$$\omega_0 = \frac{1}{\sqrt{L_{CBR}C}} \quad (44)$$

If $L_{CBR}=0$, then $k_c = 1$.

The time to peak t_{pC} is obtained from curves in the IEC standard. If $L_{CBR}=0$, then $t_{pC}=0$. The rise time constant is:

$$\tau_{1C} = k_{1C}t_{pC} \quad (45)$$

where k_{1C} is obtained from curves in IEC standard. The decay time constant is:

$$\tau_{2C} = k_{2C}R_{CBR}C \quad (46)$$

where k_{2C} is obtained from curves in IEC standard.

Example 4

A 120-V, 100 μ F capacitor has $R_{CBR}=0.05\ \Omega$ and $L_{CBR}=10$ mH. Find the terminal fault profile. From Equation (44):

$$\frac{1}{\delta} = \frac{2 \times 10 \times 10^{-3}}{0.05} = 0.4$$

Also,

$$\omega_0 = \frac{1}{\sqrt{10 \times 10^{-3} \times 100 \times 10^{-6}}} = 1000$$

From curves in the IEC standard, $k_c = 0.92$. The peak current from Equation (43) is calculated as $(0.92) \times (120/0.05) = 2208$ A. The time to peak from curves in IEC is 0.75ms, and $k_{ic} = 0.58$. From Equation (45), the rise time constant is $(0.58) \times (0.75) = 0.435$ ms. Also, $k_{2C} = 1$, and, from Equation (46), the decay time constant is 5 μ s. The fault current profile is presented in Figure 7(d).

TOTAL FAULT CURRENT

The total fault current at fault F_1 (Figure 3) is the sum of the partial fault currents calculated from the different sources. For assessment of the total fault current at F_2 (Figure 3), the partial currents from each source should be determined by adding the resistance and inductance of the common branch to the equivalent circuit. A correction factor is then used. The correction factors for every source are found from:

$$i_{pcorj} = \sigma_j i_{pj}$$

$$i_{kcorj} = \sigma_j i_{kj} \quad (47)$$

where the correction factor σ_j is specified in the IEC standard.

Example 5

The sources in previous examples are connected together in a system presented in Figure 3. In order to plot the total fault current, profiles of the partial currents presented in the Figure 7 are summed. Since the time to peak, magnitudes, and decay time constants are different in each case, a graphical method is used and the total current profile is presented in Figure 11. The peak current is roughly 27.3 kA, and the peak occurs at roughly 9ms after the fault. The fault current from the rectifier predominates. The fault current from the capacitor is a high rise pulse, which quickly decays to zero. The DC motor fault current rises slowly. Smaller DC motors have bigger armature inductance, resulting in a slower rate of current rise. The rectifier current peaks roughly in one half-cycle of the power system frequency. The relative magnitudes of the partial currents can vary, depending on the system arrangement. This can give different total current and time to peak profiles.

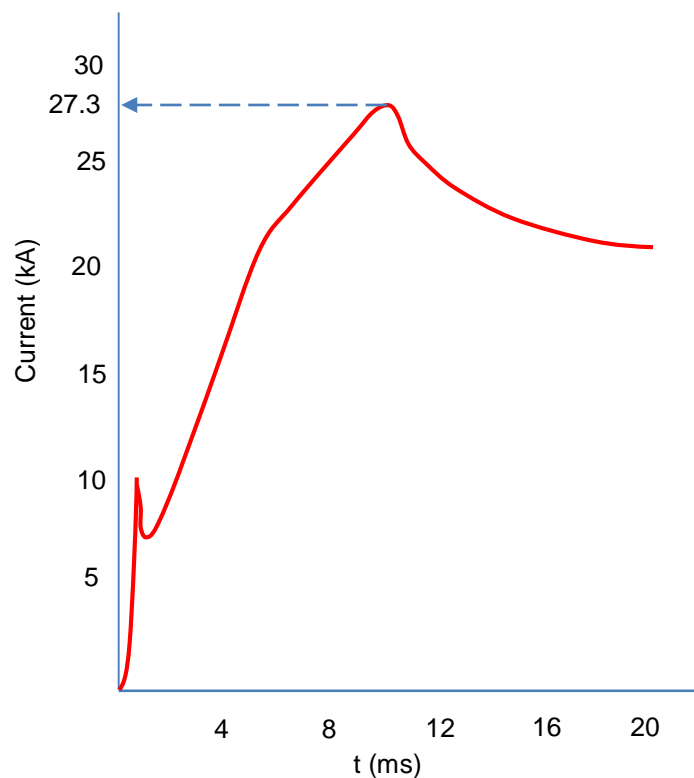

Figure 11. Total fault current profile of four partial short -circuit currents

DC CIRCUIT BREAKERS AND FUSES

The DC breakers may be classified as follows:

- The general-purpose low voltage DC power circuit breakers do not limit the peak current and may not stop the prospective fault current rise to its peak value. These designs demand a peak, short - time, and short - circuit current rating. Circuit breakers that have a continuous current rating of 2000 A and below have instantaneous elements designed to trip at 15 times the breaker rated continuous current. Circuit breakers rated above 2000 A contain instantaneous elements designed to trip at 12 times the breaker continuous current rating.
- A semi-high speed circuit breaker does not limit the short-circuit current on circuits with minimal inductance, but becomes current limiting for highly inductive circuits. This approach also demands a peak rating.
- A high-speed breaker during current breaking limits the peak to a value lower than the available (perspective) current, and these breakers have a short-circuit rating and short-time rating.
- Semi-high speed and high speed circuit breakers contain direct acting instantaneous elements set at no more than four times the circuit breaker continuous current rating or at the maximum setting below the available allowable current of the test circuit.
- Rectifier circuit breakers are a separate class, and these transfer the normal current output of one rectifier. During short circuit conditions function to withstand or break abnormal currents is needed. Rectifier breaker needs to be rated for fault current peak for $n-1$ rectifiers and a short-time current rating for its own rectifier. The circuit breakers for rectifier applications are equipped with reverse current trips, set at no more than 50% of the continuous current rating.

The DC breakers may have thermal magnetic or electronic trip elements, that is, general-purpose circuit breakers of 2 kA or lower are equipped with instantaneous tripping parts set to trip at 15 times the rated continuous current, and breakers rated > 2 kA have instantaneous trips set to trip at 12 times the rated current. Two or three breaker poles may be connected in series for increased interrupting rating. The breaker interrupting capacity decreases with rising DC voltage. The maximum inductance for total interrupting rating in micro-henries is set, and the decreased interrupting rating for inductance higher values can be determined. When the breakers are rated for AC as well as DC installations, the interrupting rating on DC systems is much lower. IEEE Standard presents the preferred ratings, associated requirements, and application suggestions for low-voltage AC (<635 V) and DC (<3200 V) power circuit breakers. Table 1 is based upon these figures.

Table 1. Ratings of general purpose DC power circuit breakers with or without instantaneous direct acting trip parts

Circuit breaker frame size (A,DC)	System nominal voltage (V, DC)	Rated maximum voltage (V, DC)	Rated peak current (A, peak)	Rated maximum short circuit current or rated short circuit current (A)	Maximum inductance for full interrupting rating (uH)	Load circuit stored energy factor (kW-s)	Range of trip device current ratings (A, DC)
600-800	250	300	41000	25000	160	50	40-800
1600	250	300	83000	50000	80	100	200-1600
2000	250	300	83000	50000	80	100	200-2000
3000	250	300	124000	75000	50	140	2000-3000
4000	250	300	165000	100000	32	160	4000
5000	250	300	165000	100000	32	160	5000
6000	250	300	165000	100000	32	160	6000

Example 6

A general-purpose DC circuit breaker for the fault at F₁ in Figure 3 and short-circuit current profile presented in Figure 11, is selected as follows:

The peak fault current is 27.5 kA, and the quasi-steady state current is roughly 22 kA. The continuous load current of all the sources (200AH DC battery, 15-HP DC motor and 100 kVA rectifier) is roughly 380 A. Hence, choose a 250 V, 600 A circuit breaker frame size, continuous current = 400 A, rated peak current = 41 kA, rated

maximum fault current or short-time current = 25 kA, as can be seen in the first row in the Table 1. The maximum inductance for full interrupting rating is determined as 160 μ H. The peak fault current is 27.5 kA, hence, the resistance is 4.36 m Ω . The time constant of the current from the rise time is roughly 4 ms, which gives $L=17.4 \mu$ H. If the inductance surpasses the value presented in Table 1, the decreased interrupting rating is obtained from the expression:

$$I = 10^4 \sqrt{\frac{20W}{L}}$$

where W is the value of kW -s shown in Table 1, L is the actual inductance in μ H, and I is in amperes.

The peak current rating can be only applied to circuit breakers in solid state rectifier installations. Rated fault current can be only applied to circuit breakers without instantaneous direct acting trip part (short time delay elements or remote relay).

DC RATED FUSES

DC rated fuses up to 600 V and interrupting ratings of 200 kA can be used. The manufacturers may not present the fault ratings at all the DC voltages, but if a fuse of required interrupting rating and rated for higher voltage is chosen at the lower DC voltage of application, the interrupting capability will be bigger.

ARCING IN DC INSTALLATIONS

The minimum voltage to preserve an arc depends upon current magnitude, gap width and electrode orientation, Figure 12 (a) and Figure 12(b) present V–I characteristics for horizontal and vertical arcs. In these figures, the transition point is determined as:

$$I_t = 10 + 0.2Z_g \quad (48)$$

where the gap Z_g is in millimeters. The V-I curves present the arc voltage both below and above the transition point. The current voltage relation is determined by:

$$V_{arc} = (20 + 0.534Z_g)I_{arc}^{0.12} \quad (49)$$

This gives an arc resistance:

$$R_{arc} = \frac{20+0.534Z_g}{I_{arc}^{0.88}} \quad (50)$$

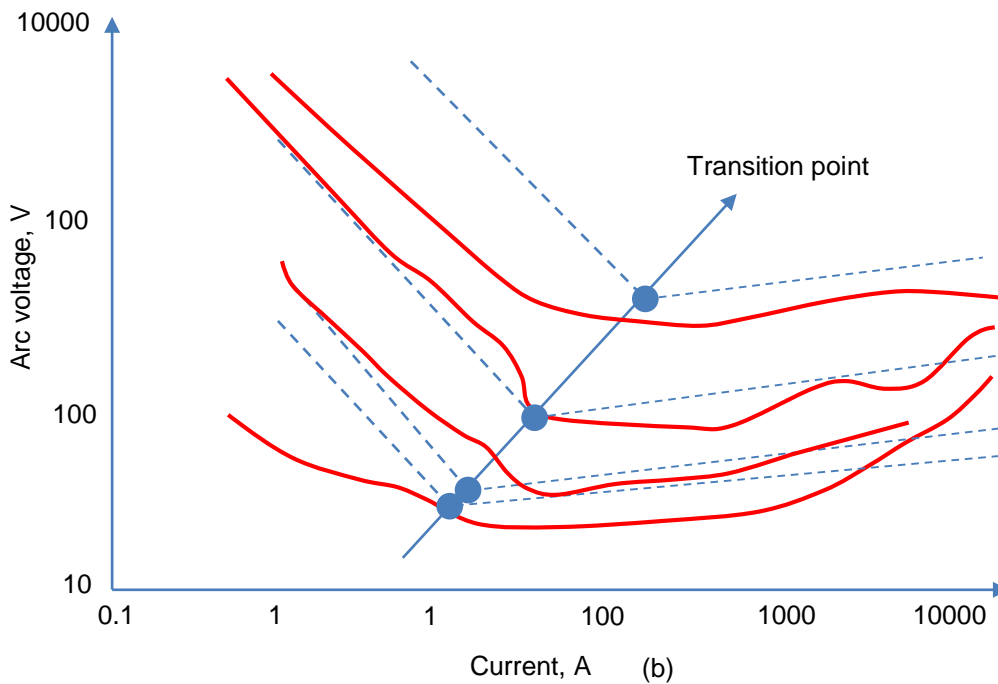
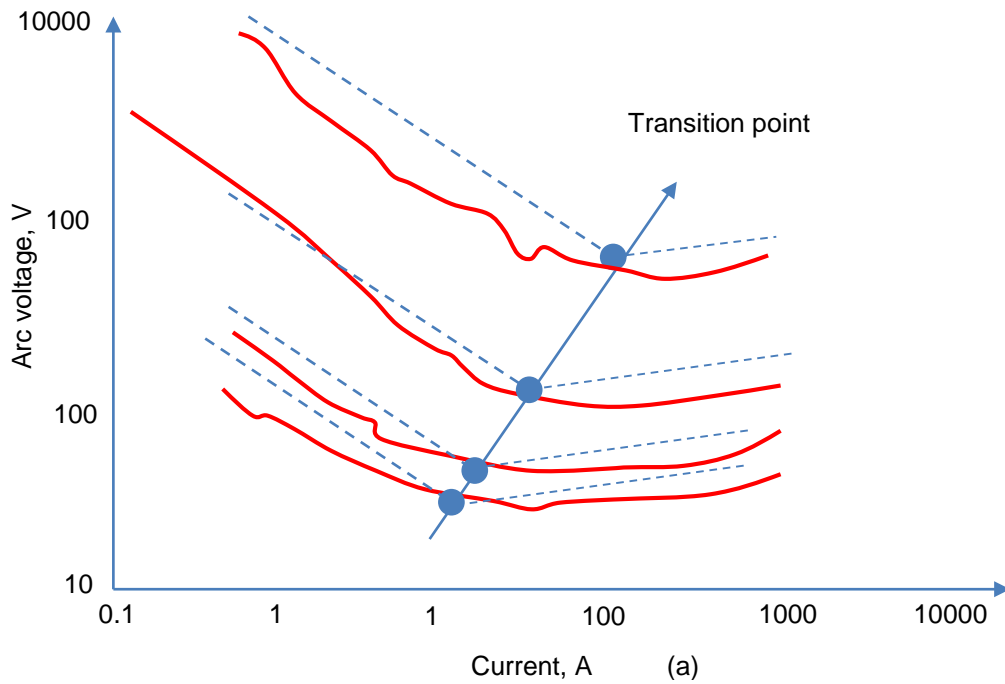

Figure 12. (a) Minimum arc voltage for vertical arcs (b) Minimum arc voltage for horizontal arcs

A simplified arc model can be completed as presented in Figure 13. If the arc resistance is zero, this provides the bolted DC current.

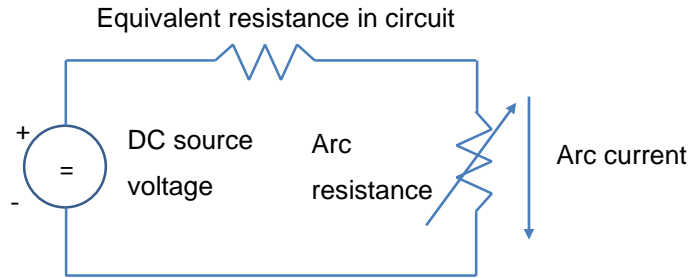

Figure 13. A simplified DC system arcing model

Example 7

Using the Equation (49) and Equation (50) and the arc model presented in Figure 13, find and plot the arcing current of the total fault current profile. The procedure is completed by calculating arc flash current at three points, A, B, and C at 9, 6, and 2ms, respectively as presented in Figure 14. The bolted currents obtained at these points from the fault profile are 27.5, 22.2, and 10.0 kA, respectively.

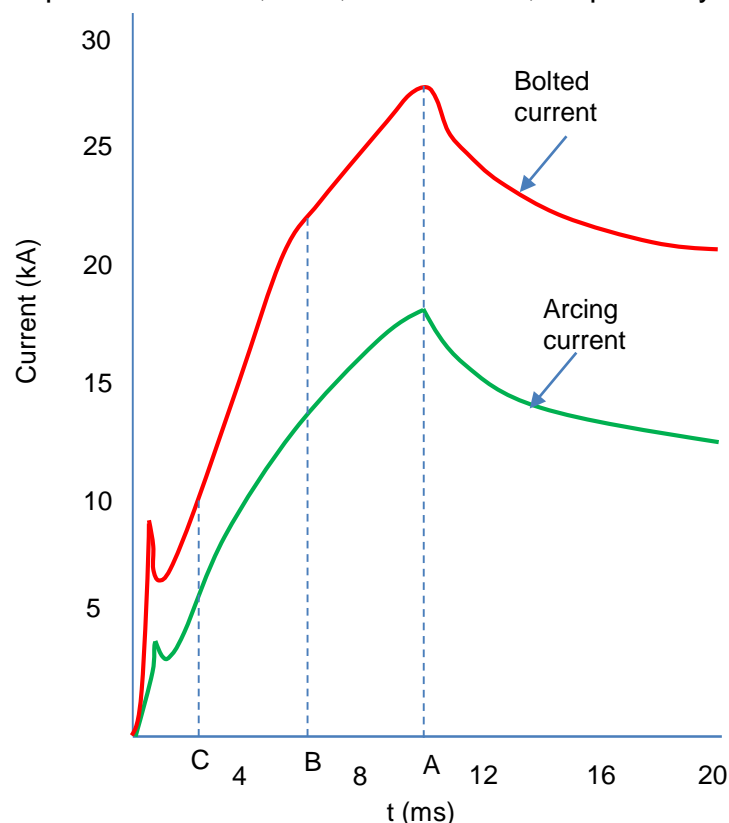

Figure 14. Arcing current profile superimposed on the fault current profile of Figure 11.

If the arc fault resistance presented in Figure 13 is zero, there is bolted current. Therefore, equating arc fault resistance to zero, the equivalent system resistance

can be determined. To determine the arc fault resistance, an iterative solution is needed using Figure 13 and Equation (50). For bolted short circuit current of 27.5 kA at point A, the calculated arcing current is determined as 17.56 kA in Figure 14. Assume, an arcing current roughly 50% or higher. Here we start with an assumption of 15 kA (Table 2).

Table 2. Iterative arcing current calculation at point A (27.5 kA) in Figure 11

Iteration No.	Arcing current (kA)	Arcing resistance (mΩ)	Total resistance (mΩ)	Calculated arcing current
1	15 (assume)	2.83	7.19	16.68
2	16.68	2.57	6.93	17.30
3	17.30	2.497	6.856	17.50
4	17.50	2.472	6.832	17.56

Table 3. Calculations of arcing current and arcing resistance

At point marked in Figure 14	Time (ms)	Bolted current (kA)	Equivalent fault resistance (mΩ)	Final arcing resistance (mΩ)	Arcing current (kA)	Arcing current as % of bolted current
A	9	27.5	4.36	2.472	17.56	63.8
B	6	22.2	5.41	2.97	14.20	63.96
C	2	10	12.20	0.553	6.80	68.0

The arc gap of 20 mm is taken into account. With these two parameters set, R_{arc} is determined from Equation (50). Sum up the arc resistance and the equivalent system resistance and find the arcing current. Reiterate with the new value of arc current, until the desired tolerance is reached. This gives 17.56 for point A (Table 3). In a similar way, the calculations at points B and C can be done. The arcing current at sufficient number of points is found, and a curve of the arcing current can be drawn (Figure 14). Table 3 presents calculations at three selected points A, B, and C.

Example 8

A 1000-A class L fuse, rated for 500 VDC, breaking current 100 kA, is installed to a common bus served by the four DC sources. Find the arcing time. A fuse TCC plot is presented in Figure 15. This is for the AC current. Manufacturers do not provide characteristics for the DC currents. Nevertheless, roughly the AC rms current can be considered same as DC current as far as heating effects are concerned. When exposed to DC currents with specific time constants, the fuse operating time will be greater and the characteristics curve will move to the right of the current axis. The 60-cycle AC wave rises to peak in 8.33ms. Hence, if the DC fault circuit is peaking in 8–10ms, no correction to the AC operating time characteristics is needed. When exposed to much slow-rising DC currents, the time–current curve will shift towards right and the operating time will increase. This increased operating time will be a function of the DC current rise time, the slower the rise, the more delayed the fuse operation. The fault profile in Figure 14 indicates that the peak is reached in roughly 9ms. Therefore, the fuse AC current curve can be used. A simple procedure will be to find the operating time based upon the incremental change in the fault current to which the fuse is exposed. Then take the weighted average to determine the average current to which the fuse is exposed. The peak arcing current is 17.56 kA and happens at 9ms. In the case this current remains same for 39ms, the fuse will trip. Nevertheless, at 14.0ms, it decreases to 14.2 kA.

Table 4. Average current calculation through the fuse

Time (ms)	Arcing current (kA)	Fuse operating time (ms)
2	6.8	300 (ignore)
6	14.24	70
9	17.56	39
14	14.00	70
20	13.0	90
≥45	12.0	100

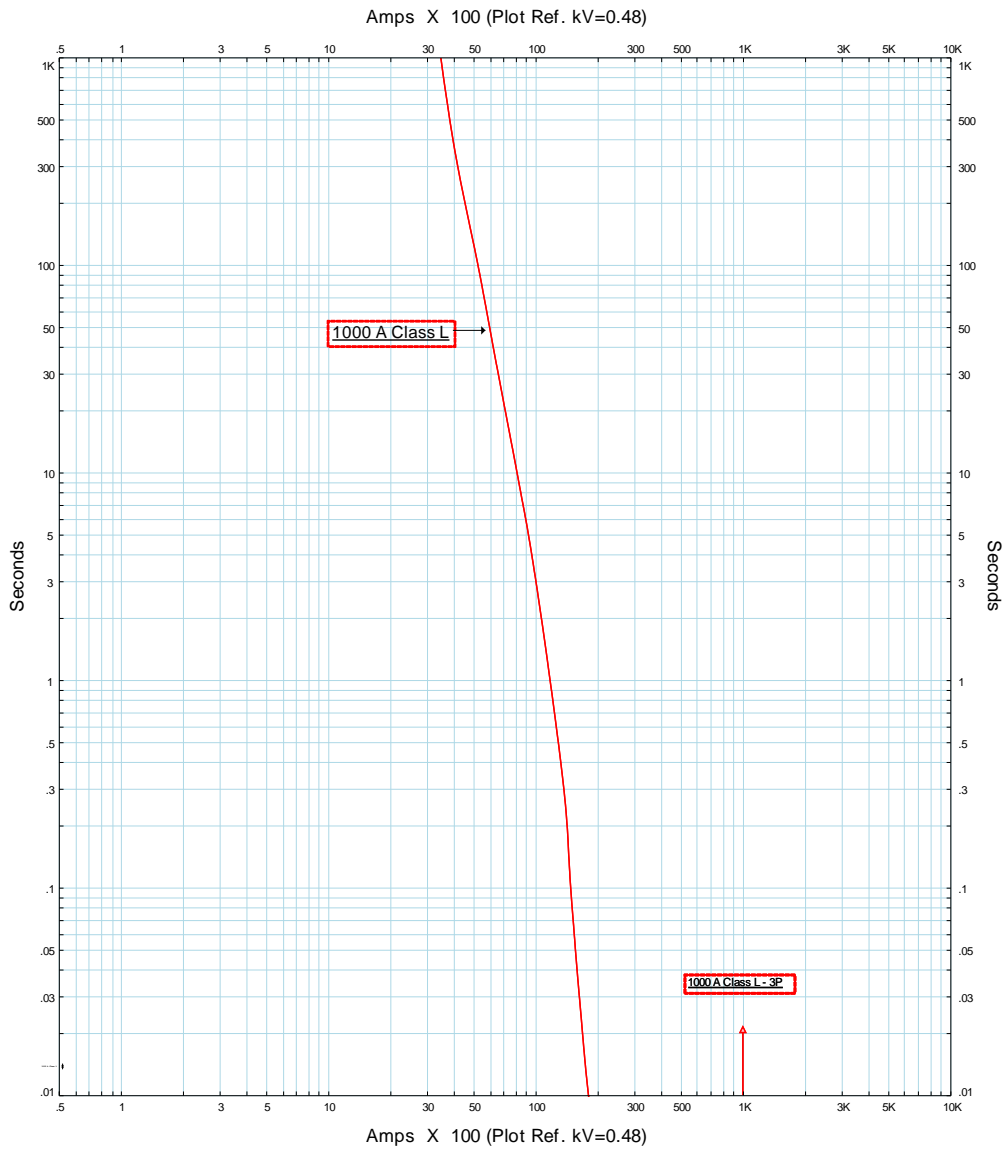

Figure 15. Time –current curve of a 1000-A fuse, class L

If this current remains for 70ms the fuse will trip. At 6ms, the current is 14.20 kA (Table 4). Therefore, in the fuse operating range, an average arcing current of 13 kA can be considered between 6ms to roughly 96ms, and the fuse trips in roughly 90ms after the current has increased to 14.2 kA at 6ms. Referring to Figure 1, the IEC formulas give results of peak and quasi-steady-state currents. The capacitor charging current is a pulse, but the currents from the other sources can be maintained. Assuming that the quasi-steady-state current continues, until it is broken down, short-circuit duration T_k , it will be conservative to conclude that the selected fuse will trip in roughly 90ms.

INCIDENT ENERGY CALCULATIONS IN DC SYSTEMS

The power in DC or single-phase arcs can be calculated as:

$$P_{arc} = V_{arc}I_{arc} = I_{arc}^2R_{arc} \quad (51)$$

Hence, the arc energy can be expressed from:

$$E_{arc} = I_{arc}^2R_{arc}t_{arc}J \quad (52)$$

where t_{arc} is the arcing time in seconds, I_{arc} is in amperes, R_{arc} in ohms. This further gives the energy in watt-seconds or joules. To change to calories, multiply by a factor of 0.239

$$E_{arc} = 0.239I_{arc}^2R_{arc}t_{arc} \text{ cal} \quad (53)$$

Radiant heat transfer is:

$$E_s = \frac{E_{arc}}{4\pi d^2} \text{ cal/cm}^2 \quad (54)$$

where d is the distance from arc in cm.

When an arc is started in an enclosure, it has the focusing effect on the energy. The spherical density part is replaced by a value E_1 , which considers the focusing effect of the enclosure:

$$E_1 = k \frac{E_{arc}}{a^2+d^2} \quad (55)$$

The values of a and k are presented in Table 5.

Table 5 Values of a and k

Enclosure	Width (mm)	Height (mm)	Depth (mm)	a (mm)	K
Panel board	305	356	191	100	0.127
LV switchgear	508	508	508	400	0.312
MV switchgear	1143	762	762	950	0.416

Example 9

Moving on with Example 8, determine the incident energy release, arcing current profile and protection through a 1000 A, class L fuse. Similarly to calculations for decaying AC fault currents - the procedure can be applied for DC arc flash assessment, with rising short-circuit currents. Average arcing current of 13 kA and arcing time of 90ms is calculated in Example 8. This further gives an arcing resistance of 3.21mΩ. From Equation (53):

$$E_{arc} = 0.239(13.0)^2 \times 10^6 \times 3.21 \times 10^{-3} \times -0.09 = 11668.9 \text{ cal}$$

From Equation (54) and considering $d=18 \text{ in}=45.7 \text{ cm}$, $E_s = 0.444 \text{ cal/cm}^2$. In this assessment, we ignored the energy during the first 6ms, when the current increases to 14.2 kA. Roughly, if an average current of 7.1kA is considered, with an arcing resistance of 3.13mΩ, it adds 226 J to the E_{arc} calculated above. This will give $E_s=0.453 \text{ cal/cm}^2$. To find the hazard level in an enclosure, use Equation (55). This equation gives:

$$E_1 = 0.127 \frac{11668.9}{10^2 + 45.7^2} = 0.68 \text{ cal/cm}^2$$

The calculated incident energy levels are low.

Example 10

A three phase rectifier is connected on the AC side to a 2400-V primary system, with a fault current of 30 kA and $X/R=15$. The rectifier transformer is sized at 2000 kVA, 2.4-0.48 kV, percentage impedance 5.5, $X/R=7.5$. While neglecting smoothing reactor or secondary cable connection impedances, find the DC fault current on the 480-V bus, the arcing current, and the incident energy release. Using the procedure and equations shown in previous examples, fault and arcing current profile is presented in Figure 16. A 20 mm gap is considered. Note that the peak fault current is 103.8 kA, and the peak arcing current is 92 kA=88.6% of the peak fault current. NFPA 70E calculations suggest that the arcing current can be considered=50% of the fault current. The NFPA regulations are only approximate based on maximum power transfer theorem, and can lead to severe errors. Considering an average arcing current of 46 kA, until it reaches its peak value of 92 kA, the arc resistance is 1.06 mΩ. Then the energy release in 11.2ms, until the arcing current reaches its peak is:

$$(0.239)(46)^2 \times 10^6 \times (1.06) \times 10^{-3} \times (11.2 \times 10^{-3}) = 6004 \text{ cal}$$

At a distance of 18 in, the incident energy release is 0.229 cal/cm². This can be accomplished if a fast current-limiting semiconductor fuse is given, which isolates the fault before reaching the peak arcing current of 92 kA. The fuse will trip in less than 1/2 cycle, faster than 11.2ms arcing time considered above. Actually, the fuse will limit the peak to less than 92 kA and trip even faster, therefore the energy release will be much less than computed above. Another point is that the arcing cannot begin

when the current is rising from zero value. It has to reach a minimum value for the arc to start. If a circuit breaker that is not current limiting and allows the peak to pass through is applied, the quasi-steady-state current, say 55 kA in Figure 16 can be considered for arc flash assessment. This current magnitude gives an arcing resistance of 0.902m Ω . A three-cycle breaker opening time gives: $E_{arc}=32606$ cal and $E_s=1.242$ cal/cm². This assessment is for arcing in the open air. For arcing in an enclosure, low voltage switchgear, the calculated values are:

- 0.507 cal/cm² - semiconductor fuse
- 2.76 cal/cm² - three cycle circuit breaker allowing the peak to pass through.

NFPA suggests that for enclosed equipment, energy equal to twice the energy calculated in open air can be used, regardless of the equipment type.

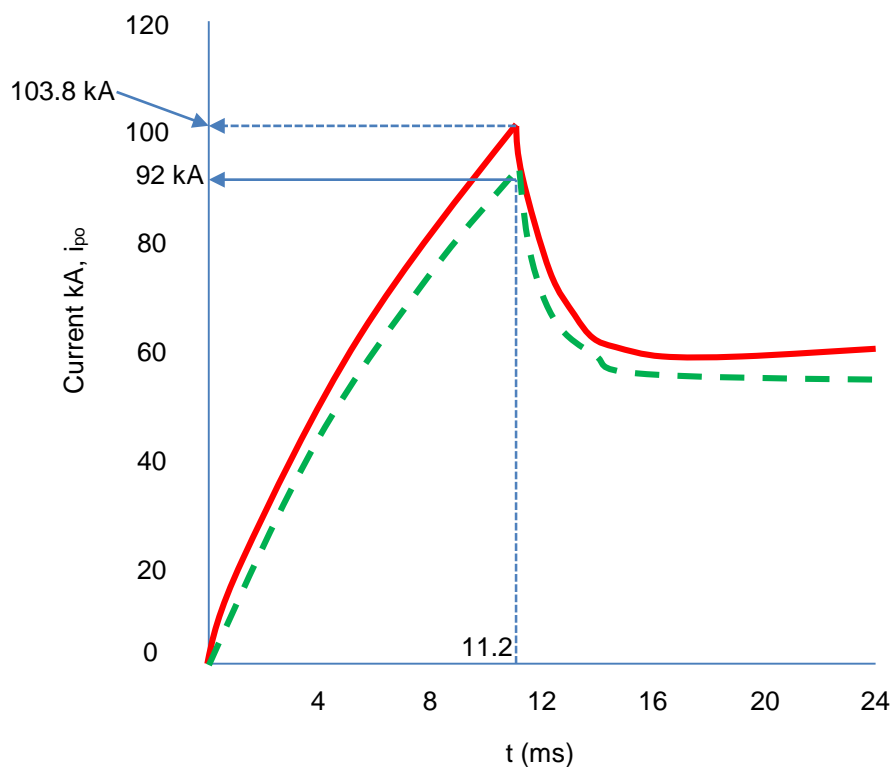

Figure 16. Calculated short -circuit and arcing current profiles for Example 10

SEMICONDUCTOR DEVICE PROTECTION

The semi-conducting equipment like diodes, SCRs, GTOs, must not be damaged by fault currents. Unlike motors, transformers or underground cables, these do not have sufficient thermal withstand capability. Invariably, these are protected by high speed

I^2t limiting current limiting fuses or circuit breakers. These work fast within less than a cycle and limit the I^2t let-through. This I^2t of the fuse is coordinated with the device I^2t capability of the semi-conducting element.

A manufacturer's information on fast acting and I^2t limiting fuses for semiconductor equipment include:

- Application voltage - 450VDC
- Current range 35 – 1000 A
- Interrupting rating 79 kA
- For a 1000 A fuse clearing $I^2t = 500,000 \text{ A}^2\text{s}$.

Similar information for a 1200A fuse is:

- Application voltage 500VDC,
- Current range 10–1200A,
- Interrupting rating 100 kA, for a 1200 A fuse
- Clearing $I^2t=100,000 \text{ A}^2\text{s}$ melting $I^2t=800,000 \text{ A}^2\text{s}$.

Note that a 1200A semiconductor fuse is used for the protection of semiconductor equipment. Then from Equation (52), the maximum energy release can be calculated as:

$$E_{arc} = 900,000 \times R_{arc}$$

Here, we replace 900,000 A^2s from the fuse data.

R_{arc} decreases with the increase of arcing current. The maximum energy release is: 215 cal and $E_s=0.008 \text{ cal/cm}^2$. In an enclosure approximately double the calculated value= 0.16 cal/cm^2 .

CONTROLLED CONVERTERS

The converters with network control can be called controlled converters, and most of these in practical installations are controlled converters, firing angle adjustable from $0 < \alpha < 180^\circ$ (angles $> 90^\circ$ relate to inverter operation). Yet the variable speed drive (VSD) system may have front-end uncontrolled bridge rectifier circuit. The damage for a fault current in a controlled converter system is limited by network-control protection arrangements. This allows a network firing circuit to discover abnormal

conditions and block grid pulses. The current flow to a converter fault is limited to one cycle by the normal action of the grid control protection arrangements. Figure 17 presents the DC fault in a full-wave SCR converter where the network protection system is in service operative.

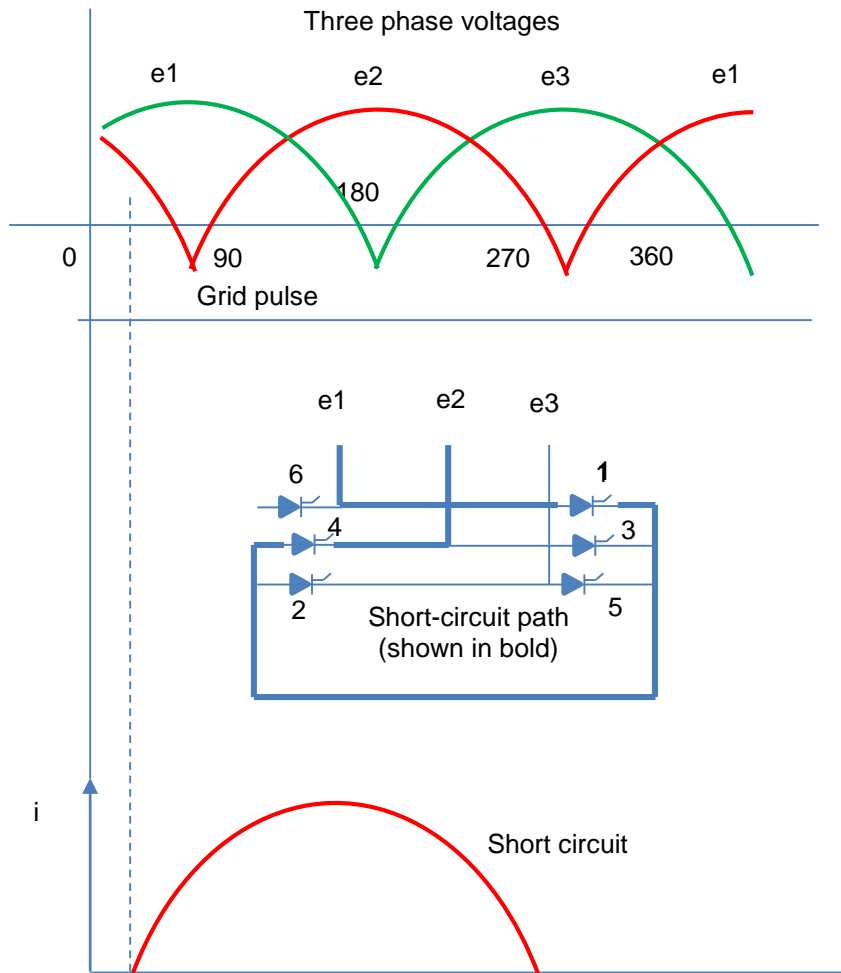

Figure 17. Converter with grid (gate) control - fault current

Example 11

A network-controlled full-wave converter gives a peak DC fault current of 100 kA. Find the incident energy release. Let the arcing current peak be around 85% of the maximum fault current, the fault profile a sinusoid, and the average arcing current 54 kA. The incident energy release for a period of 16.67ms is 215.53 cal, and E_s is 0.0082 cal/cm². The above assessment and calculations show that the arc flash energy in DC systems is low because of the requirement of protecting the semiconductor equipment through fast acting fuses and circuit breakers or by

network control. Yet a case-by-case assessment needs to be completed, and the results may differ with respect to protective equipment used and the system arrangements. DC motor fault clearance time will be bigger in comparison battery or rectifier circuit. One such example is solar generation. The fault current contributed by a solar array is small. According to vendor's information:

- Rated output power: 235 W
- Rated open circuit voltage: 37 V
- Maximum operating current: 7.97 A
- Maximum fault current: 8.54 A.

The fault current is not much higher than the rated current. When such solar arrays are assembled to give 600 VDC and 125 A load current ratings, and the assembly is connected through an inverter to the 480-V power system, fault contributed by the inverter will be cleared by the fast acting protective equipment, but the current from the solar arrays will continue to supply the fault. Much akin to AC system arc flash assessment, where each element of the total fault current may be cleared at different time intervals, depending upon the protective elements in these circuits; a similar approach is needed for calculation from several DC sources. To repeat, a case-by-case assessment needs to precisely determine (1) fault and arcing currents, (2) the time–current and current limiting characteristics of protective equipment, (3) converter grid controls, and (4) peak and quasi steady state fault currents to determine the operation time.